

Прессы карусельные для отделки одежды МАСРІ 506.00.2053+967

Технические характеристики

Алматы (7273)495-231
Ангарск (3955)60-70-56
Архангельск (8182)63-90-72
Астрахань (8512)99-46-04
Барнаул (3852)73-04-60
Белгород (4722)40-23-64
Благовещенск (4162)22-76-07
Брянск (4832)59-03-52
Владивосток (423)249-28-31
Владикавказ (8672)28-90-48
Владимир (4922)49-43-18
Волгоград (844)278-03-48
Вологда (8172)26-41-59
Воронеж (473)204-51-73
Екатеринбург (343)384-55-89

Иваново (4932)77-34-06
Ижевск (3412)26-03-58
Иркутск (395)279-98-46
Казань (843)206-01-48
Калининград (4012)72-03-81
Калуга (4842)92-23-67
Кемерово (3842)65-04-62
Киров (8332)68-02-04
Коломна (4966)23-41-49
Кострома (4942)77-07-48
Краснодар (861)203-40-90
Красноярск (391)204-63-61
Курск (4712)77-13-04
Курган (3522)50-90-47
Липецк (4742)52-20-81

Магнитогорск (3519)55-03-13
Москва (495)268-04-70
Мурманск (8152)59-64-93
Набережные Челны (8552)20-53-41
Нижний Новгород (831)429-08-12
Новокузнецк (3843)20-46-81
Ноябрьск (3496)41-32-12
Новосибирск (383)227-86-73
Омск (3812)21-46-40
Орел (4862)44-53-42
Оренбург (3532)37-68-04
Пенза (8412)22-31-16
Петрозаводск (8142)55-98-37
Псков (8112)59-10-37
Пермь (342)205-81-47

Ростов-на-Дону (863)308-18-15
Рязань (4912)46-61-64
Самара (846)206-03-16
Саранск (8342)22-96-24
Санкт-Петербург (812)309-46-40
Саратов (845)249-38-78
Севастополь (8692)22-31-93
Симферополь (3652)67-13-56
Смоленск (4812)29-41-54
Сочи (862)225-72-31
Ставрополь (8652)20-65-13
Сыктывкар (8212)25-95-17
Тамбов (4752)50-40-97
Сургут (3462)77-98-35
Тверь (4822)63-31-35

Тольятти (8482)63-91-07
Томск (3822)98-41-53
Тула (4872)74-02-29
Тюмень (3452)66-21-18
Ульяновск (8422)24-23-59
Улан-Удэ (3012)59-97-51
Уфа (347)229-48-12
Хабаровск (4212)92-98-04
Чебоксары (8352)28-53-07
Челябинск (351)202-03-61
Череповец (8202)49-02-64
Чита (3022)38-34-83
Якутск (4112)23-90-97
Ярославль (4852)69-52-93

Россия (495)268-04-70

Казахстан (772)734-952-31

Киргизия (996)312-96-26-47

Side seams opening

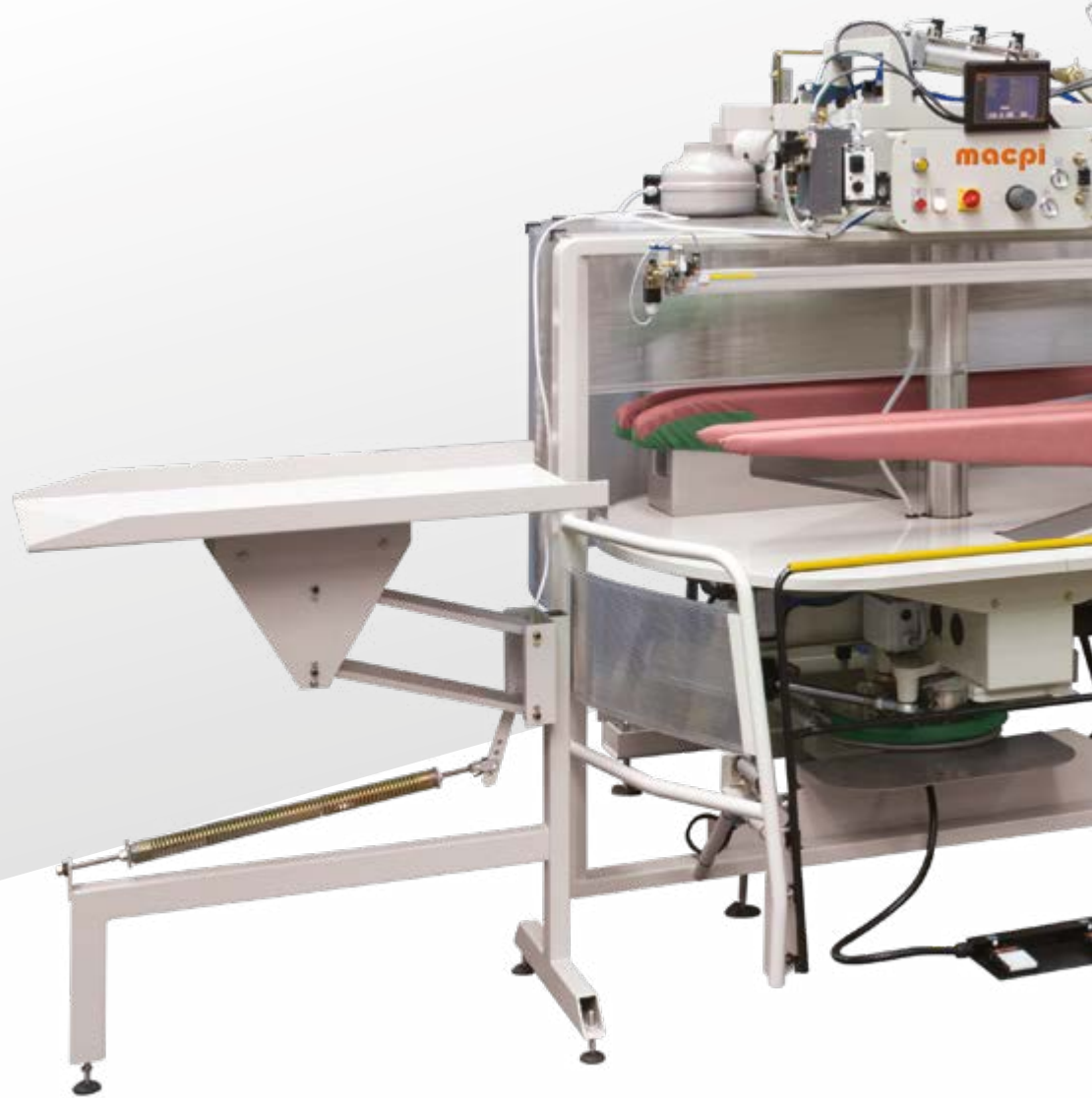

Piano di carico mobile bilanciato, che permette di avere l'altezza (H) del pacco di prelievo sempre costante.
Balanced loading area that allows the constant height (H) of the pack.

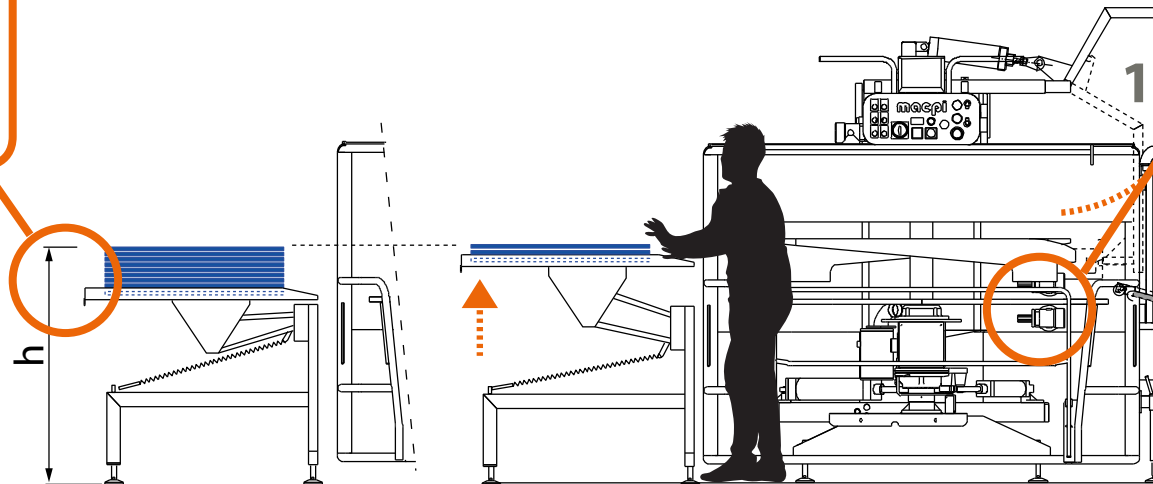

506.00.2053+967



Attrezzatura per lo scarico delle gambe dei pantaloni, composta da un braccio di L=1750 con spostamento angolare (1), su cui è montata una doppia pinza che a fine corsa, in estrazione, ruota di 90° (2), ripositiona il pantalone (3) (4) permettendo al pezzo scaricato di depositarsi sul trasportatore per l'accumulo singolo o di pacchi (5).

Unloader for trousers legs consisting of one arm 1750 mm. long (1), with a double clamp and end-stroke rotating of 90°. (2), repositions the trousers (3) (4) allowing the unloaded piece to settle on the conveyor forming a single accumulation or packages (5).

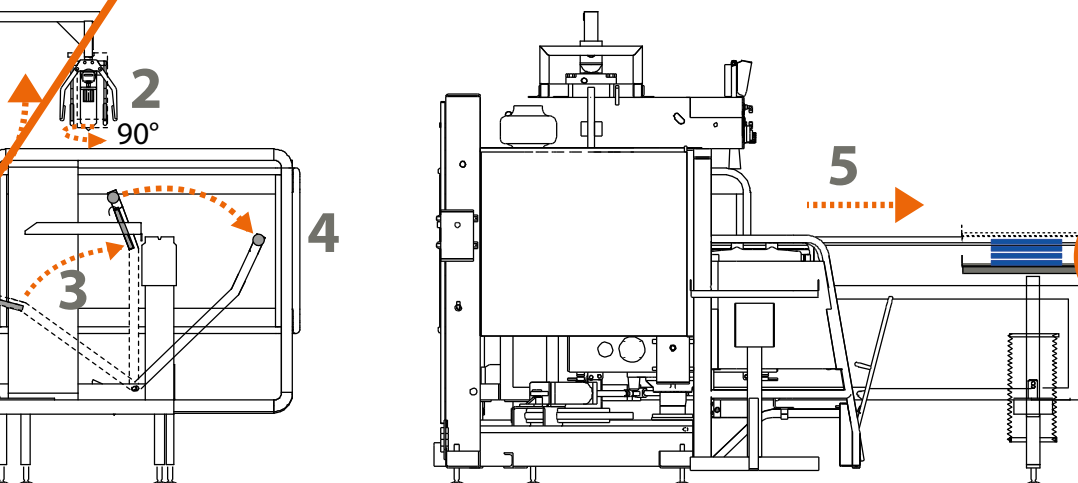

Piano di riallineamento fondo pantaloni per aggancio pacco a trasporto aereo
Realignment plan for trousers turn-up for attaching the packages to air transport.

Side seams opening

Ergonomics - Safety

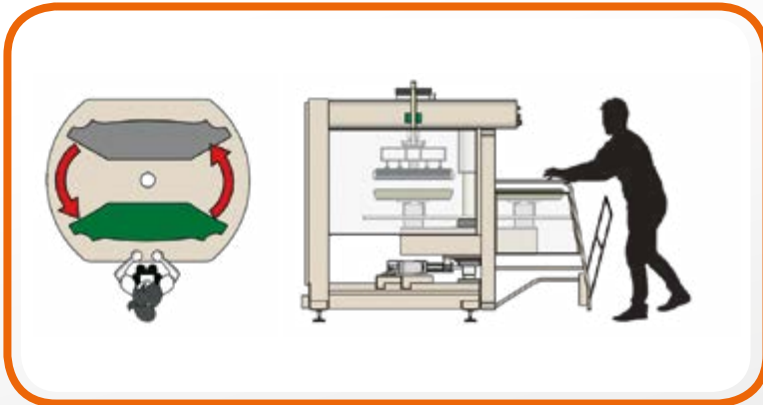

La sicurezza è garantita da un cancelletto che, oltre a formare una barriera fisica tra operatore e macchina, impedisce il movimento rotatorio delle forme inferiori se non inserito.

The safety is granted by a gate which is a physical barrier between the operator and the machine. Furthermore it stops the rotation movement of the buck shapes if it's not operating properly.

Pressing

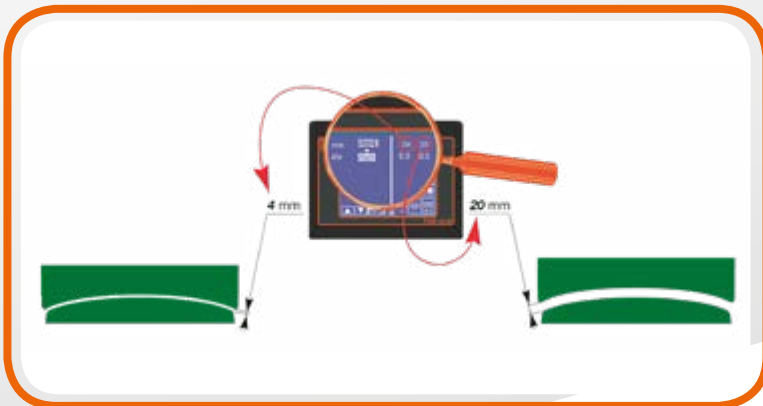

I caroselli macpi sono dotati, di serie (per le forme previste), di un dispositivo elettronico per la regolazione di precisione della forma superiore in posizione di pressatura o sfumatura per garantire la massima qualità con qualsiasi tipologia di tessuto e spessore. A discrezione dell'operatore il dispositivo può fissare il nuovo punto zero, adeguando automaticamente tutti i parametri preimpostati. Macpi carousels are fitted (for the foreseen shapes) with electronic device for the precision adjustment of the upper shape in sponging or pressing position to grant the best quality with any kind of fabric and thickness. This device can fix the new zero point, automatically setting the new parameters in according to the operator's request.

Rotating

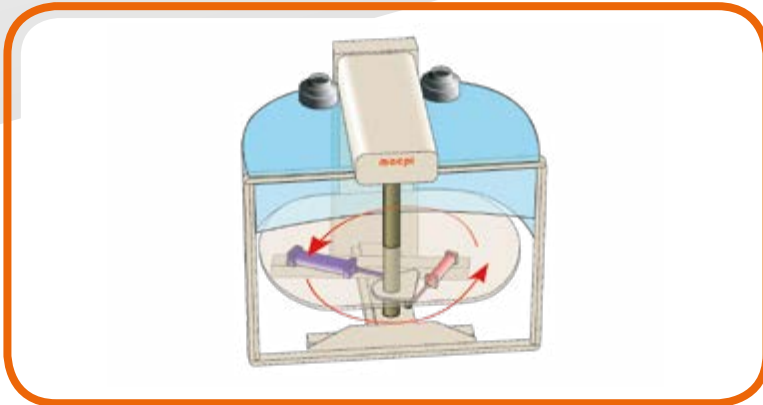

L'applicazione di sistemi, pneumatici di spinta e oleodinamici di frenata, direttamente sugli organi di rotazione del carosello, permette di ottenere eccezionali prestazioni sulla velocità di rotazione e sulla precisione di frenata.

Thanks to the special pneumatic lift and stop by oleo gear systems, speed rotation and stop precision performances are very high.

Suction Hood



Di serie i caroselli macpi montano un sistema di cappe aspiranti che ha la funzione di eliminare il vapore in eccesso, mantenendo l'ambiente di lavoro più fresco senza aggiunta di costi per la climatizzazione.

MACPI carousels are fitted with suction hood which eliminates the exceeding steam, maintaining the working place cooler without any further costs for air-conditioning.

506.00.2053+967



506.00.2053+967

Carosello per l'apertura e lo stiro delle cuciture interno esterno gamba del pantalone.

La macchina Carosello 506 consente di aumentare la produzione senza perdere la qualità: mentre l'operatore apre le cuciture delle gambe su una forma, all'interno della macchina avviene lo stiro delle cuciture dell'altra gamba, pertanto il tempo di ciclo viene coperto dal tempo di preparazione. Usando il carosello abbiamo diversi vantaggi:

facilità di posizionamento, pressatura verticale regolabile elettronicamente, cappa per aspirare eccessi vapore.

Il carosello 506 può essere anche dotato di alcuni sistemi per aumentarne la produttività:

- scaricatore automatico ed impilatore
- sistema di carico a molle che predispose il pacco di pantaloni sempre alla stessa altezza
- supporto ferro con ritorno automatico.



506.00.2053+967

Carousel machine designed for inner/outer legs seams opening.

The machine allows a drastic increase of production output without affecting the finishing quality: while the operator is positioning the legs for the seam busting, the other side the machine is operating so the pressing cycle time is always balanced by the positioning/handling time. Additional advantages given by the unit 506 are:

easy positioning, vertical pressing electronically adjustable, suction hoods to remove excess steam.

In order to increase its productivity, the machine can be supplied upon request with the following device:

- automatic off-loader with stacker
- spring loading plate in order to level the trousers bundle at the same height of the shapes
- iron stand with automatic return movement.

Technical details

555.+967 Dimension: (mm W x H x D) 4250 x 1950 x 2810 | **Weight:** 1030 Kg

Compressed air: pipe connection 1x \varnothing 10 mm | **Pressure** 6 ATE | **Consumption** 70NL/min

Electric power: 0,3Kw | **Consumption** 0,2Kw/h

Steam: pipe connection 1x \varnothing 1/2" GAS | **Pressure** 5 ATE | **Consumption** 25Kg/h

Note: size, consumption, weight, depend from specific model

Алматы (7273)495-231
Ангарск (3955)60-70-56
Архангельск (8182)63-90-72
Астрахань (8512)99-46-04
Барнаул (3852)73-04-60
Белгород (4722)40-23-64
Благовещенск (4162)22-76-07
Брянск (4832)59-03-52
Владивосток (423)249-28-31
Владикавказ (8672)28-90-48
Владимир (4922)49-43-18
Волгоград (844)278-03-48
Вологда (8172)26-41-59
Воронеж (473)204-51-73
Екатеринбург (343)384-55-89

Иваново (4932)77-34-06
Ижевск (3412)26-03-58
Иркутск (395)279-98-46
Казань (843)206-01-48
Калининград (4012)72-03-81
Калуга (4842)92-23-67
Кемерово (3842)65-04-62
Киров (8332)68-02-04
Коломна (4966)23-41-49
Кострома (4942)77-07-48
Краснодар (861)203-40-90
Красноярск (391)204-63-61
Курск (4712)77-13-04
Курган (3522)50-90-47
Липецк (4742)52-20-81

Магнитогорск (3519)55-03-13
Москва (495)268-04-70
Мурманск (8152)59-64-93
Набережные Челны (8552)20-53-41
Нижний Новгород (831)429-08-12
Новокузнецк (3843)20-46-81
Ноябрьск (3496)41-32-12
Новосибирск (383)227-86-73
Омск (3812)21-46-40
Орел (4862)44-53-42
Оренбург (3532)37-68-04
Пенза (8412)22-31-16
Петрозаводск (8142)55-98-37
Псков (8112)59-10-37
Пермь (342)205-81-47

Ростов-на-Дону (863)308-18-15
Рязань (4912)46-61-64
Самара (846)206-03-16
Саранск (8342)22-96-24
Санкт-Петербург (812)309-46-40
Саратов (845)249-38-78
Севастополь (8692)22-31-93
Симферополь (3652)67-13-56
Смоленск (4812)29-41-54
Сочи (862)225-72-31
Ставрополь (8652)20-65-13
Сыктывкар (8212)25-95-17
Тамбов (4752)50-40-97
Сургут (3462)77-98-35
Тверь (4822)63-31-35

Тольятти (8482)63-91-07
Томск (3822)98-41-53
Тула (4872)74-02-29
Тюмень (3452)66-21-18
Ульяновск (8422)24-23-59
Улан-Удэ (3012)59-97-51
Уфа (347)229-48-12
Хабаровск (4212)92-98-04
Чебоксары (8352)28-53-07
Челябинск (351)202-03-61
Череповец (8202)49-02-64
Чита (3022)38-34-83
Якутск (4112)23-90-97
Ярославль (4852)69-52-93

Россия (495)268-04-70

Казахстан (772)734-952-31

Киргизия (996)312-96-26-47