

Станки электропневматические для отделки брюк без складок МАСРІ 320.00

Технические характеристики

Алматы (7273)495-231
Ангарск (3955)60-70-56
Архангельск (8182)63-90-72
Астрахань (8512)99-46-04
Барнаул (3852)73-04-60
Белгород (4722)40-23-64
Благовещенск (4162)22-76-07
Брянск (4832)59-03-52
Владивосток (423)249-28-31
Владикавказ (8672)28-90-48
Владимир (4922)49-43-18
Волгоград (844)278-03-48
Вологда (8172)26-41-59
Воронеж (473)204-51-73
Екатеринбург (343)384-55-89

Иваново (4932)77-34-06
Ижевск (3412)26-03-58
Иркутск (395)279-98-46
Казань (843)206-01-48
Калининград (4012)72-03-81
Калуга (4842)92-23-67
Кемерово (3842)65-04-62
Киров (8332)68-02-04
Коломна (4966)23-41-49
Кострома (4942)77-07-48
Краснодар (861)203-40-90
Красноярск (391)204-63-61
Курск (4712)77-13-04
Курган (3522)50-90-47
Липецк (4742)52-20-81

Магнитогорск (3519)55-03-13
Москва (495)268-04-70
Мурманск (8152)59-64-93
Набережные Челны (8552)20-53-41
Нижний Новгород (831)429-08-12
Новокузнецк (3843)20-46-81
Ноябрьск (3496)41-32-12
Новосибирск (383)227-86-73
Омск (3812)21-46-40
Орел (4862)44-53-42
Оренбург (3532)37-68-04
Пенза (8412)22-31-16
Петрозаводск (8142)55-98-37
Псков (8112)59-10-37
Пермь (342)205-81-47

Ростов-на-Дону (863)308-18-15
Рязань (4912)46-61-64
Самара (846)206-03-16
Саранск (8342)22-96-24
Санкт-Петербург (812)309-46-40
Саратов (845)249-38-78
Севастополь (8692)22-31-93
Симферополь (3652)67-13-56
Смоленск (4812)29-41-54
Сочи (862)225-72-31
Ставрополь (8652)20-65-13
Сыктывкар (8212)25-95-17
Тамбов (4752)50-40-97
Сургут (3462)77-98-35
Тверь (4822)63-31-35

Тольятти (8482)63-91-07
Томск (3822)98-41-53
Тула (4872)74-02-29
Тюмень (3452)66-21-18
Ульяновск (8422)24-23-59
Улан-Удэ (3012)59-97-51
Уфа (347)229-48-12
Хабаровск (4212)92-98-04
Чебоксары (8352)28-53-07
Челябинск (351)202-03-61
Череповец (8202)49-02-64
Чита (3022)38-34-83
Якутск (4112)23-90-97
Ярославль (4852)69-52-93

Россия (495)268-04-70

Казахстан (772)734-952-31

Киргизия (996)312-96-26-47

Automatic unit with unloader for jeans



Stiro a vapore contemporaneo delle tasche e patella
Contemporary pressing of flap and pockets

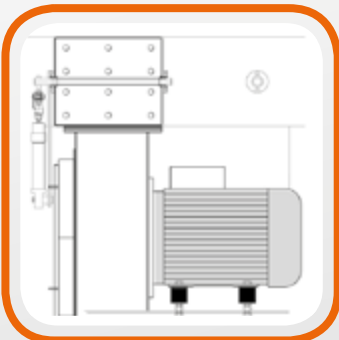

Motore per soffiaggio da 3 Hp
3 Hp motor for strong blowing



Programmatore touch-screen a colori TCW 7" con porta USB e Wi-fi
Full color touch screen programmer TCW 7" with USB and Wi-fi



Risparmio dello spazio, alta produttività e qualità, risparmio energetico
Space saving, high productivity and quality, energy savings

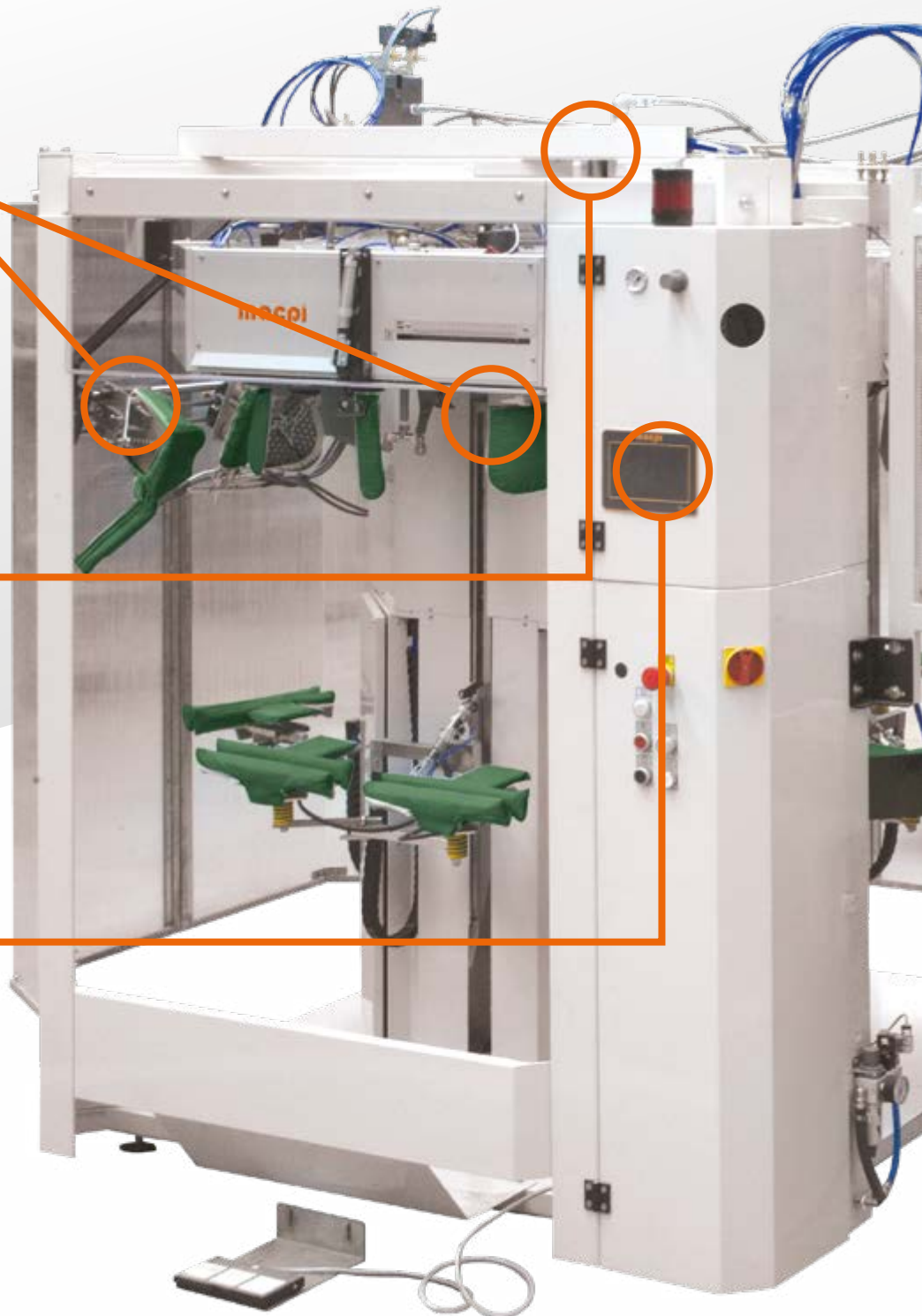

320. | 949.

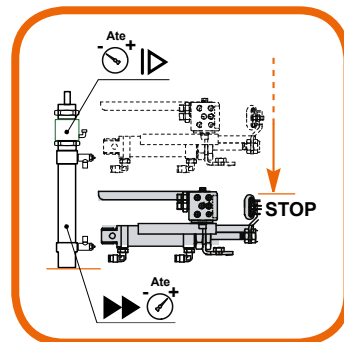
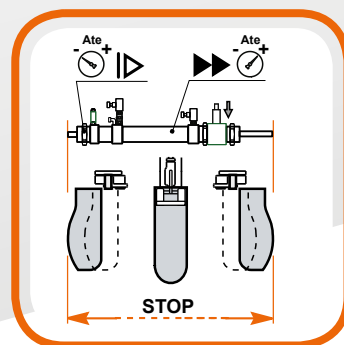

Dispositivo tensione bacino e gamba antistretch, con doppio cilindro per alta velocità e estrema sensibilità per tessuti elasticizzati e blocco meccanico.

Antistretch device for top and leg, double cylinder with mechanical block for high speed and extreme sensitivity for stretching fabrics

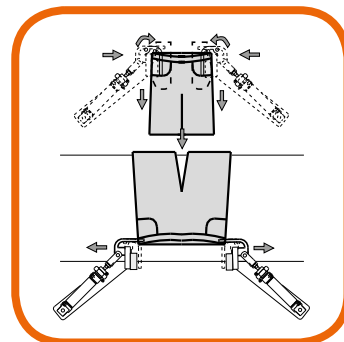

Scarico automatico pantaloni, con apparecchiatura per un preciso prelievo e perfetta distensione del pantalone.

Automatic unloader with device for precise packing and perfect positioning

Automatic unit with unloader for jeans

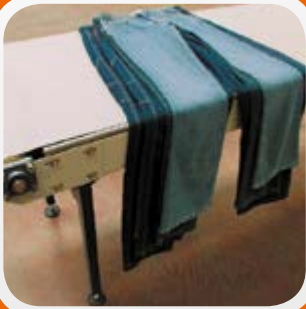
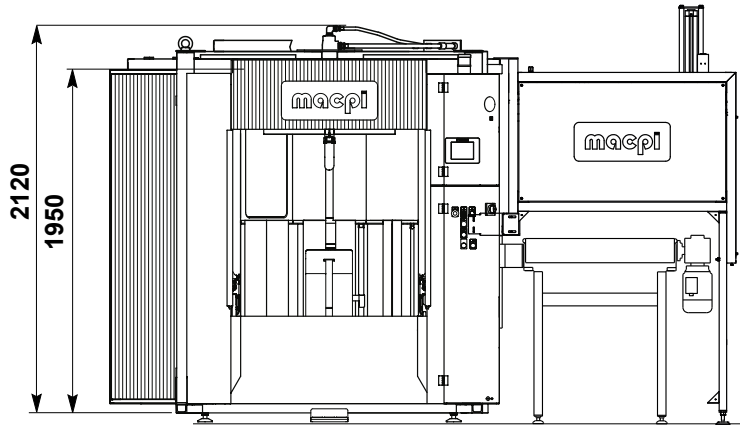

Lo scarico automatico deposita i capi stirati su nastro trasportatore nelle modalità a pezzo singolo o con formazione di pacchi.

The automatic unloader deposits the finished pants on the conveyor belt on single-piece or on packs

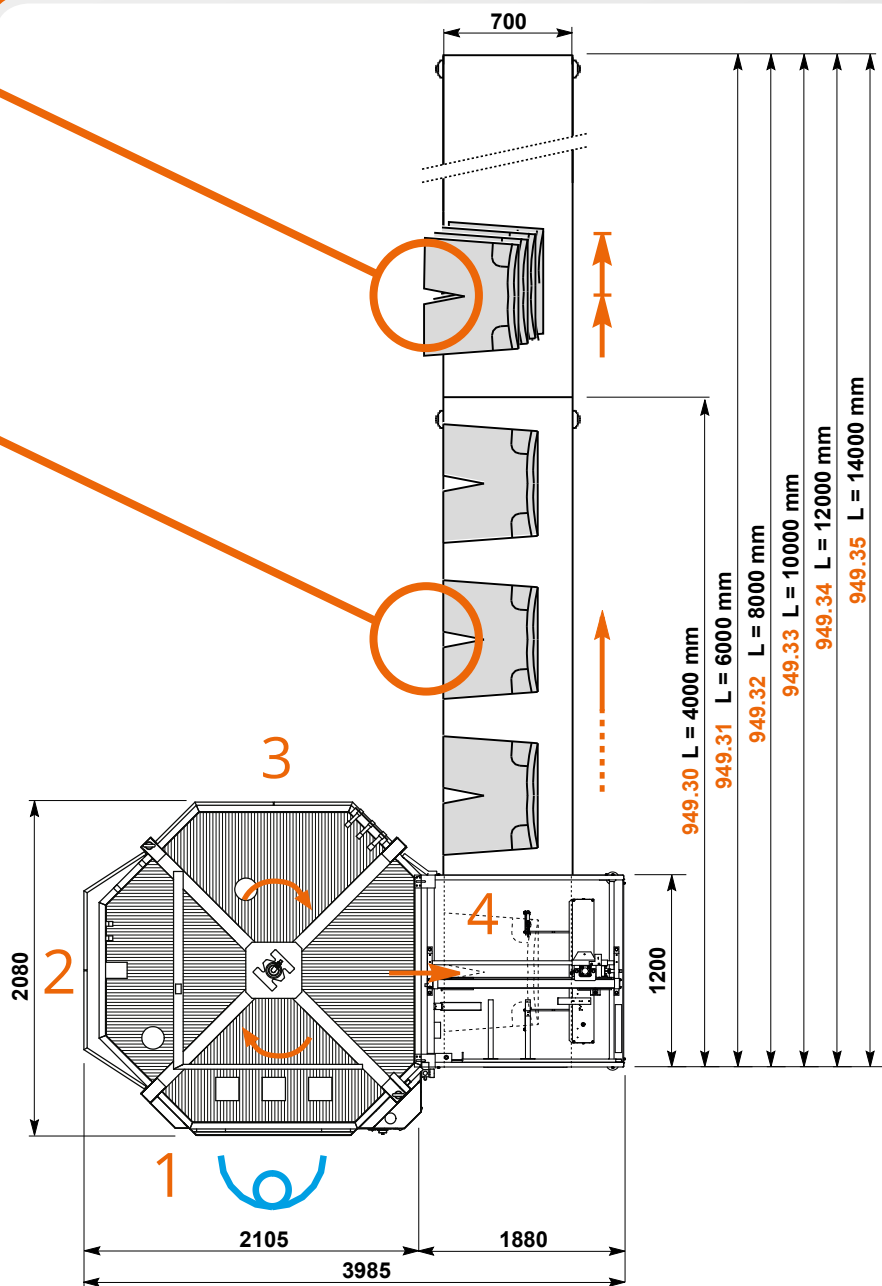

1 Stazione di CARICO
LOADING station

2-3 SOFFIAGGIO
BLOWING

4 Stazione di SCARICO
UNLOADING station

**320.00****STIRO PANTALONE SENZA PIEGA**

Topper elettropneumatico per lo stiro dei pantaloni senza piega, predisposto per le applicazioni della messa in taglia del bacino e della lunghezza della gamba. Possibilità di stiro patella e tasche anteriori. L'unità automatica è completa di:

- sistema di controllo a colori TCW 7" con USD e Wi-Fi
- 4 stazioni vaporizzanti e soffianti montate su tavola rotante
- forme bacino sagomate. La tensione viene esercitata sui fianchi del bacino del pantalone
- di serie sono montate le forme sagomate medie (a richiesta in alternativa, possono essere montate le altre forme sotto elencate)
- carrello per tensione gamba con regolazione meccanica per poter stirare sia pantaloni corti/baby che taglie massime uomo (possibilità di messa in taglia della gamba variando posizione di carico verso l'alto)
- regolazione pneumatica della tensione gambe e bacino con sensore per blocco della posizione
- regolazione portata vaporizzazione
- dispositivo regolazione portata soffiaggio
- dispositivo blocco patella e cintura posteriore
- gruppo pinze fondo gambe orientabile e oscillante
- surriscaldatore del vapore
- soffiaggio con elettroventilatore Kw 2,25
- riscaldamento aria/soffiaggio
- regolazione pressione pinze fondo pantaloni
- programmazione elettronica tempi di vaporizzazione, ritardo soffiaggio, soffiaggio e apertura anticipata delle pinze
- contapezzi

CONNESSIONI

- Allacciamento aria compressa 6 ate
- Allacciamento fonte vapore 6 ate

Potenza installata Kw 2,45 Voltaggio: 3~50Hz 400 V

**320.00****FINISHING OF TROUSERS WITHOUT PLEATS**

Electro-pneumatic unit for the finishing of trouser without pleats, suitable for the application of top and legs sizing device. Possibility of front flap and front pocket pressing.

The unit is complete with:

- color device TC W7" with USD and Wi-Fi
- four steaming and blowing stations fitted on rotating plate
- shaped medium size plate for top. The tension is released on the trouser top sides. Standard shape fitted on the machine (pls see below for other available shapes on request)
- trouser tensioning device by mechanical adjustment for pressing both babies short and large size men's trousers (possibility of legs sizing changing loading position)
- pneumatic adjustment for legs and tops tensioning by a sensor for position locking
- adjustable steaming flow
- device to adjust air blowing flow
- front flap blocking device and rear belt
- adjustable and tilting legs clamps
- steam over-heater
- air blowing by electric fan (Kw. 2,25)
- air/blowing heating
- adjustable clamps pressure
- electronic time set-up for steaming, air blowing delay, air blowing and anticipated clamps opening
- production counter

Connection:

- Connection to air blowing 6 Atm
- Connection to steam 6 Atm

Installed Power Kw. 2,45 Voltage: 3~50Hz 400 V

Technical details

- 320.00** **Dimension:** (mm W x H x D) 2105 x 2120 x 2080 | **Weight:** 1000 Kg
Compressed air: pipe connection 1x ø10 mm | **Pressure** 6 ATE - consumption 140NL/min
Steam: pipe connection 1x ø3/4" GAS | **Pressure** 6 ATE - consumption 70 KG/h
Electric power: 3,5 Kw - consumption 2,45 Kw/h

Алматы (7273)495-231
Ангарск (3955)60-70-56
Архангельск (8182)63-90-72
Астрахань (8512)99-46-04
Барнаул (3852)73-04-60
Белгород (4722)40-23-64
Благовещенск (4162)22-76-07
Брянск (4832)59-03-52
Владивосток (423)249-28-31
Владикавказ (8672)28-90-48
Владимир (4922)49-43-18
Волгоград (844)278-03-48
Вологда (8172)26-41-59
Воронеж (473)204-51-73
Екатеринбург (343)384-55-89

Иваново (4932)77-34-06
Ижевск (3412)26-03-58
Иркутск (395)279-98-46
Казань (843)206-01-48
Калининград (4012)72-03-81
Калуга (4842)92-23-67
Кемерово (3842)65-04-62
Киров (8332)68-02-04
Коломна (4966)23-41-49
Кострома (4942)77-07-48
Краснодар (861)203-40-90
Красноярск (391)204-63-61
Курск (4712)77-13-04
Курган (3522)50-90-47
Липецк (4742)52-20-81

Магнитогорск (3519)55-03-13
Москва (495)268-04-70
Мурманск (8152)59-64-93
Набережные Челны (8552)20-53-41
Нижний Новгород (831)429-08-12
Новокузнецк (3843)20-46-81
Ноябрьск (3496)41-32-12
Новосибирск (383)227-86-73
Омск (3812)21-46-40
Орел (4862)44-53-42
Оренбург (3532)37-68-04
Пенза (8412)22-31-16
Петрозаводск (8142)55-98-37
Псков (8112)59-10-37
Пермь (342)205-81-47

Ростов-на-Дону (863)308-18-15
Рязань (4912)46-61-64
Самара (846)206-03-16
Саранск (8342)22-96-24
Санкт-Петербург (812)309-46-40
Саратов (845)249-38-78
Севастополь (8692)22-31-93
Симферополь (3652)67-13-56
Смоленск (4812)29-41-54
Сочи (862)225-72-31
Ставрополь (8652)20-65-13
Сыктывкар (8212)25-95-17
Тамбов (4752)50-40-97
Сургут (3462)77-98-35
Тверь (4822)63-31-35

Тольятти (8482)63-91-07
Томск (3822)98-41-53
Тула (4872)74-02-29
Тюмень (3452)66-21-18
Ульяновск (8422)24-23-59
Улан-Удэ (3012)59-97-51
Уфа (347)229-48-12
Хабаровск (4212)92-98-04
Чебоксары (8352)28-53-07
Челябинск (351)202-03-61
Череповец (8202)49-02-64
Чита (3022)38-34-83
Якутск (4112)23-90-97
Ярославль (4852)69-52-93

Россия (495)268-04-70

Казахстан (772)734-952-31

Киргизия (996)312-96-26-47